

# 永磁交流伺服电动机规格书

## PERMANENT MAGNET AC SERVO MOTOR SPECIFICATION

版本 REV	变更号 ECN NO	变更内容 CONTENT CHANGED	处数 NO.	日期 DATE	设计 DESIGN

制动器规格	
额定电压	DC24V±10%
功率	7.6W, 20°C
静摩擦扭矩	≥1.5N.M, 20°C
衔铁吸合时间	<60ms
衔铁释放时间	<20ms

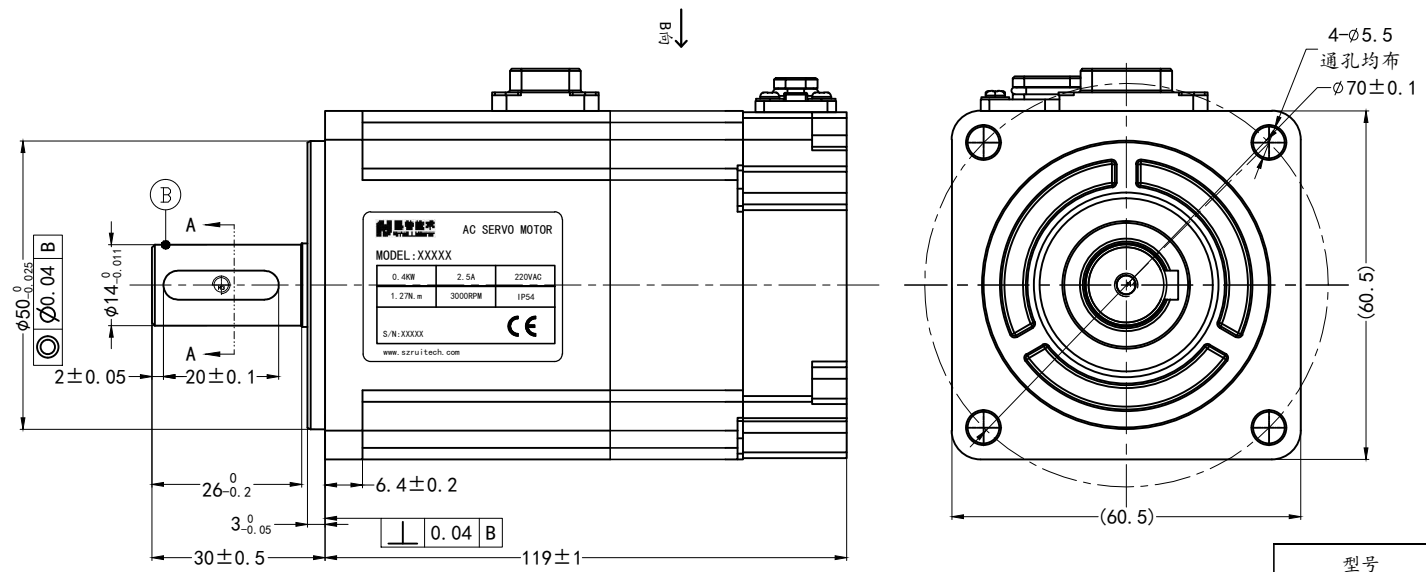

### 使用说明: Instructions

使用环境温度-20—55° C不结冰  
Operating ambient temperature -20—55 ° C no ice  
使用环境温度20%—80%RH不结露  
Operating environment humidity 20%—80%rh no condensation  
1000m以下使用, 1000m以上请降额使用, 具体参照海拔降额曲线  
For use below 1000m, please reduce the rating for use above 1000m.  
Refer to the altitude derating curve for details

### 参数列表 parameters List

额定电压 Rated Voltage (V)	220V	线电阻 Line-Line Resistance (Ω)	5.75±10% (20°C)
额定功率 Rated Power (W)	400	线电感 Line-Line Inductance (mH)	9.7±20% (20°C)
额定电流 Rated Current (A)	2.5	转动惯量 Rotor inertia (×10 <sup>-4</sup> kg/m <sup>2</sup> )	0.55
峰值电流 Peak Current (A)	5	绝缘等级 Insulation Class	F
额定转速 Rated Speed (rpm)	3000	绝缘电阻 Insulation resistance	DC1000V ≥20MΩ
最高转速 Peak Speed (rpm)	5000	防护等级 Protection class	IP65
额定转矩 Rated Torque (N.M)	1.27	允许最大径向负载 Maximum allowable radial load (N)	210
峰值转矩 Peak Torque (N.M)	2.54	允许最大轴向负载 Maximum allowable axial load (N)	50
反电势 Voltage Constant (V/Krpm)	34.6	重量 Weight (kg)	
力矩系数 Torque Coefficient (N.M/A)	0.5		

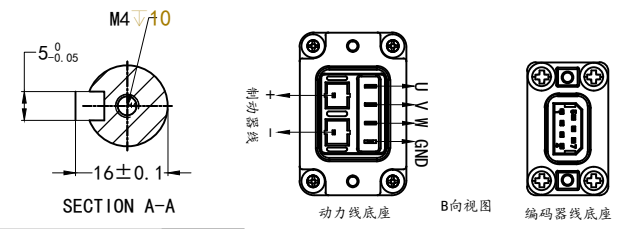

型号 Model	编码器 encoder
RSDA-M06J1330C-Z	17位单圈磁编 17 bit single coil magnetic encoder
RSDA-M06G1330C-Z	17位多圈磁编 17 bit multi coil magnetic encoder
RSDA-M06L1330C-Z	23位多圈光电 23 bit multi turn photoelectric

编码器接线顺序 (其中5、6号为多圈和光电编码器用) magnetic encoder wiring sequence (numbers 5 and 6 are used for multi turn and photoelectric encoders)							电机绕组接线顺序 Motor winding wiring sequence						
序号 Serial number	1	2	3	4	5	6	7	序号 Serial number	1	2	3	4	
颜色 Color	绿 Green	黄 Yellow	白 White	红 Red	蓝 Blue	黑 Black	屏蔽	颜色 Color	红 Red	白 White	黑 Black	黄绿 Yellow/Green	
定义 Definition	SD-	SD+	GND	VCC	BAT+	BAT-	PE	定义 Definition	U	V	W	PE	
CTQ SIGN:  Customer  Process  Law							深圳锐特机电技术有限公司 Shenzhen Rtelligent Technology Co.,Ltd						
材料符合ROHS要求 All Material Are To Be Rohs Compliant							锐特技术 RTelligent						
NAMES	SIGNATURE	DATE	Unspecified tolerance				视角 FIRST ANGLE METHOD	比例 SCALE	单位 UNIT	变更标识 ECN SIGN	名称 TITLE		
设计 DESIGN			常规公差: Tolerances 角度 Angles ±0.1° 倒角 Chamfer ±0.3					1:1	mm	*	图号 DWG.ING		
标准化 STANDARD			Unit: mm GB/T1804-M ISO2768-1 ClassM				件号 PART NUMBER	1	版本 REV	A	表单编号 Form Code		
审核 CHECK													