

# 永磁交流伺服电动机规格书

## PERMANENT MAGNET AC SERVO MOTOR SPECIFICATION

版本 REV	变更号 ECN NO	变更内容 CONTENT CHANGED	处数 NO.	日期 DATE	设计 DESIGN

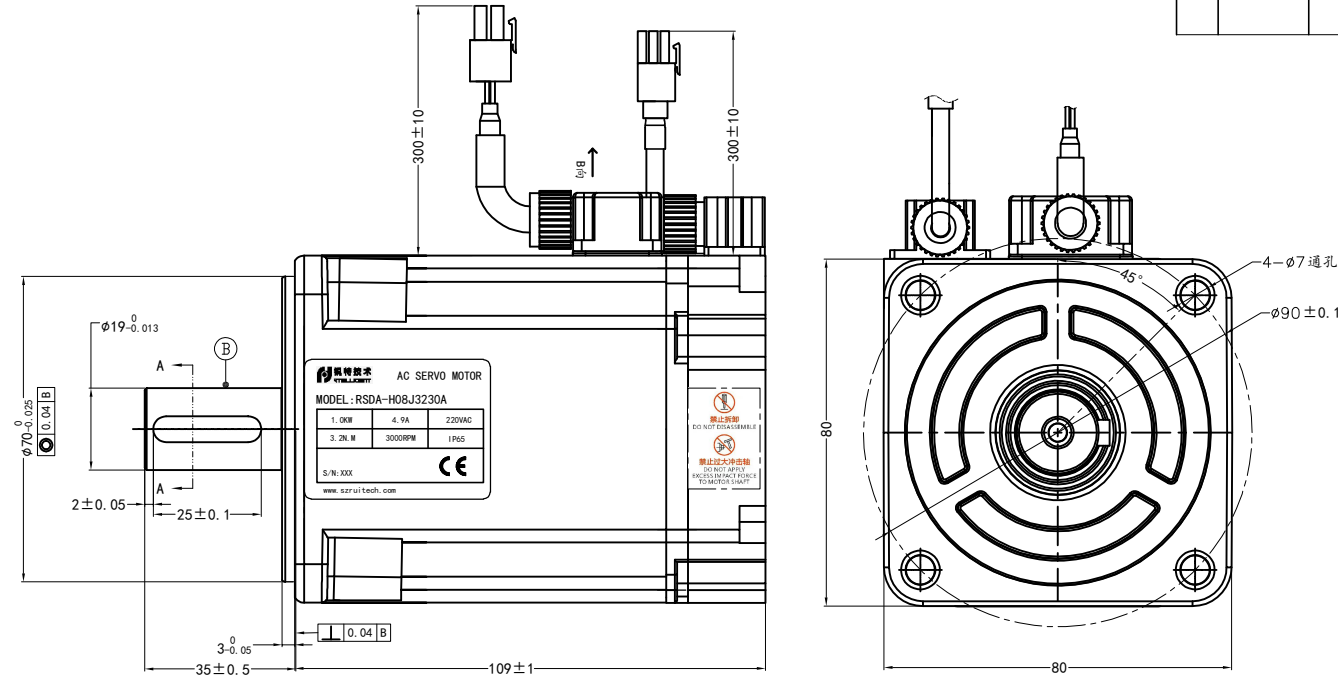

### 使用说明: Instructions

使用环境温度-20--40° C不结冰  
 Operating ambient temperature -20--40° C no ice  
 使用环境湿度20%--80%RH不结露  
 Operating environment humidity 20%--80%rh no condensation  
 1000m以下使用, 1000m以上请降额使用, 具体参照海拔降额曲线  
 For use below 1000m, please reduce the rating for use above 1000m.  
 Refer to the altitude derating curve for details

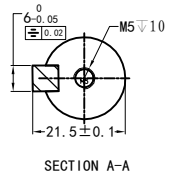

编码器线端子拉脱力<13N  
 Pull off force of encoder line terminal is less than or equal to 13N

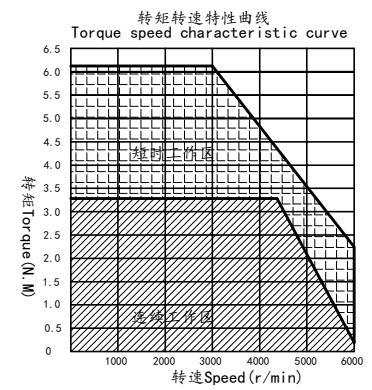
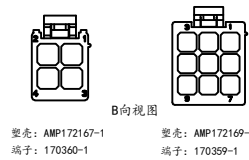

### 参数列表 parameters List

额定电压 Rated Voltage (V)	220	线电阻 Line-Line Resistance (Ω)	1.72±10% (20°C)
额定功率 Rated Power (W)	1000	线电感 Line-Line Inductance (mH)	6.5±20% (20°C)
额定电流 Rated Current (A)	4.9	转动惯量 Rotor inertia (×10 <sup>-4</sup> kg*m <sup>2</sup> )	2.0
峰值电流 Peak Current (A)	9.8	绝缘等级 Insulation Class	F
额定转速 Rated Speed (rpm)	3000	绝缘电阻 Insulation resistance	DC1000V ≥ 20MΩ
最高转速 Peak Speed (rpm)	5000	防护等级 Protection class	IP65
额定转矩 Rated Torque (N.M)	3.2	允许最大径向负载 Maximum allowable radial load (N)	390
峰值转矩 Peak Torque (N.M)	6.4	允许最大轴向负载 Maximum allowable axial load (N)	140
反电势 Voltage Constant (V/Krpm)	45.7	重量 Weight (kg)	2.4
力矩系数 Torque Coefficient (N.M/A)	0.49		

17位单圈磁编接线顺序 17-bit single-turn magnetic encoder wiring sequence							电机绕组接线顺序 Motor winding wiring sequence					
序号 Serial number	1	2	3	4	5	6	7	序号 Serial number	1	2	3	4
颜色 Color	屏蔽	红	白	黄	绿			颜色 Color	红	白	黑	黄绿
定义 Definition	PE	VCC	GND	SD+	SD-			定义 Definition	U	V	W	PE
CTQ SIGN: <input checked="" type="checkbox"/> Customer <input checked="" type="checkbox"/> Process <input checked="" type="checkbox"/> Law							深圳锐特机电技术有限公司 Shenzhen Rtelligent Technology Co.,Ltd					
材料符合ROHS要求 All Material Are To Be Rohs Compliant												
NAMES	SIGNATURE	DATE	Unspecified tolerance				视角 FIRST ANGLE METHOD	比例 SCALE	单位 UNIT	变更标识 ECN SIGN	名称 TITLE	RSDA-H08J3230A
设计 DESIGN	ZHANG	2023.5.12	常规公差: Tolerances 角度 Angles ±0.1° 倒角 Chamfer ±0.3					1:1	mm	*	图号 DWG. NO	/
标准化 STANDARD			Unit:mm GB/T1804-M ISO2768-1 ClassM				件号 PART NUMBER	1	版本 REV	A	表编号 Form Code	